



Speed controllers, 2.4 A, 0.75 kW, Sensor input 4, AS-Interface®, S-7.4 for 31 modules, HAN Q4/2, with braking resistance, STO (Safe Torque Off)



Part no. RASP5-2400A31-4120110S1
 Catalog No. 198740

Delivery program

Product range			Speed controller
Rated operational voltage	U_e		400 V AC, 3-phase 480 V AC, 3-phase
Output voltage with V_e	U_2		0 - U_{LN}
Mains voltage (50/60Hz)	U_{LN}	V	380 (-15%) - 480 (+10%)
At 150% overload	I_e	A	2.4
assigned motor rating P			
Note			at 400 V, 50 Hz
150 % Overload	P	kW	0.75
Note			at 480 V, 60 Hz
150 % Overload	P	HP	1
Note			for normal internally and externally ventilated 4 pole, three-phase asynchronous motors with 1500 rpm^{-1} at 50 Hz or 1800 min^{-1} at 60 Hz
Description			integrated PTC thermistor monitoring and Thermoclick with safe isolation Two sensor inputs through M12 sockets (max. 150 mA) for quick stop and interlocked manual operation optional: 4 sensor inputs with M12-Y adapter for switchover to creep speed Connection of supply voltage via adapter cable on round or flexible busbar junction Diagnostics and reset on device and via AS-Interface with AUTO - OFF/RESET - HAND key switches Four fixed speeds can be switched over from U/f to (vector) speed control with selector switch REV - OFF - FWD optional: Faster stop if external 24 V fails
Sensor input		Number	4
Interface/field bus (built-in)			AS-Interface®
AS-Interface profile cable			S-7.4 for 31 modules
Plug arrangement			HAN Q4/2
Braking resistance			with braking resistance
Safety function			STO (Safe Torque Off)
Parameterization			Keypad Fieldbus drivesConnect drivesConnect mobile (App)
Instructions integrated brake chopper with braking resistance for dynamic braking			

Technical data

General			
Standards			IEC/EN 61800-5-1 UL 61800-5-1 Guideline 2011/65/EU (RoHS) CE approval UL approval
Climatic proofing	ρ_w	%	< 95%, non-condensing IEC/EN 50178
Ambient temperature			
Operating ambient temperature min.		°C	-10
Operating ambient temperature max.		°C	+40
			-10 – +55 with derating
Storage	θ	°C	-40 - +70
Overtoltage category			
Rated impulse withstand voltage	U_{imp}	kV	2
Radio interference level			

Radio interference class (EMC)			C1 (for conducted emissions only), C2, C3, depending on the motor cable length, the connected load, and ambient conditions.
Environment (EMC)			1st and 2nd environments as per EN 61800-3
maximum motor cable length	l	m	C1 ≤ 1 m C2 ≤ 5 m C3 ≤ 25 m
Mechanical shock resistance		g	1000 shocks per shaft, semi-sinusoidal 15 g/11 ms IEC/EN 60068-2-27
Vibration			Oscillation frequency: 10 - 150 Hz Amplitude 0.15 mm: 6 Hz Amplitude transition frequency on acceleration: 57 Hz IEC/EN 60068-2-6
Mounting position			Vertical
Altitude		m	0 - 1000 m above sea level above 1000 m with 1 % performance reduction per 100 m max. 2000 m
Degree of Protection			IP65 NEMA12

Main circuit

Supply			
Rated operational voltage	U_e		400 V AC, 3-phase 480 V AC, 3-phase
Mains voltage (50/60Hz)	U_{LN}	V	380 (-15%) - 480 (+10%)
Input current (150% overload)	I_{LN}	A	2.5
System configuration			AC voltage Center-point earthed star network (TN-S network) Phase-earthed AC supply systems are not permitted.
Supply frequency	f_{LN}	Hz	50/60
Frequency range	f_{LN}	Hz	45–66 (± 0%)
Mains switch-on frequency			Maximum of one time every 60 seconds
Mains current distortion	THD	%	< 120
Rated conditional short-circuit current	I_q	kA	< 10
Short-circuit protection for output circuits, external			Type 1 coordination via the power bus' feeder unit
Power section			
Function			Variable frequency drive with internal DC link and IGBT inverter
On-delay	t_{ON}	ms	< 10
Off-delay	t_{OFF}	ms	< 10
Overload current (150% overload)	I_L	A	3.6
Note regarding overload current			For 60 s every 600 s at 40 °C
max. starting current (High Overload)	I_H	%	200
Note about max. starting current			at 40 °C
Output voltage with V_e	U_2		0 - U_{LN}
Output Frequency	f_2	Hz	0 - 50/60 (max. 500)
Switching frequency	f_{PWM}	kHz	8 adjustable 4 - 32
Operation Mode			U/f control sensorless vector control (SLV) PM and LSPM motors Synchronous reluctance motors BLDC motors
Frequency resolution (setpoint value)	Δf	Hz	0.1
Rated operational current			
At 150% overload	I_e	A	2.4
Note			Rated operational current at a switching frequency of 8 kHz and an ambient air temperature of +40 °C
Motor current limit	I	A	0,2 - 2,4 adjustable
Power loss			
Heat dissipation at rated operational current $I_e = 150\%$	P_V	W	32
Efficiency	η	%	97
Maximum leakage current to ground (PE) without motor	I_{PE}	mA	3.5
Fitted with			without manual override switch without fan

			with braking resistance
Safety function			STO (Safe Torque Off)
Motor feeder			
Note			for normal internally and externally ventilated 4 pole, three-phase asynchronous motors with 1500 rpm ⁻¹ at 50 Hz or 1800 min ⁻¹ at 60 Hz
Note			at 400 V, 50 Hz
150 % Overload	P	kW	0.75
Note			at 480 V, 60 Hz
150 % Overload	P	HP	1
Braking function			
Switch-on threshold for the braking transistor	U _{DC}	V	765 V DC
DC braking	%	I/I _e	≤ 100, adjustable

Control section

External control voltage	U _c	V	24 V DC - 15 % / + 20 % via AS-Interface® plug
Interface/field bus (built-in)			AS-Interface®
AS-Interface®			max. total power consumption from AS-Interface® power supply unit (30 V): 190 mA Specification: S-7.4 Number of slave addresses: 31

Design verification as per IEC/EN 61439

Technical data for design verification			
Operating ambient temperature min.		°C	-10
Operating ambient temperature max.		°C	40

Dimensions

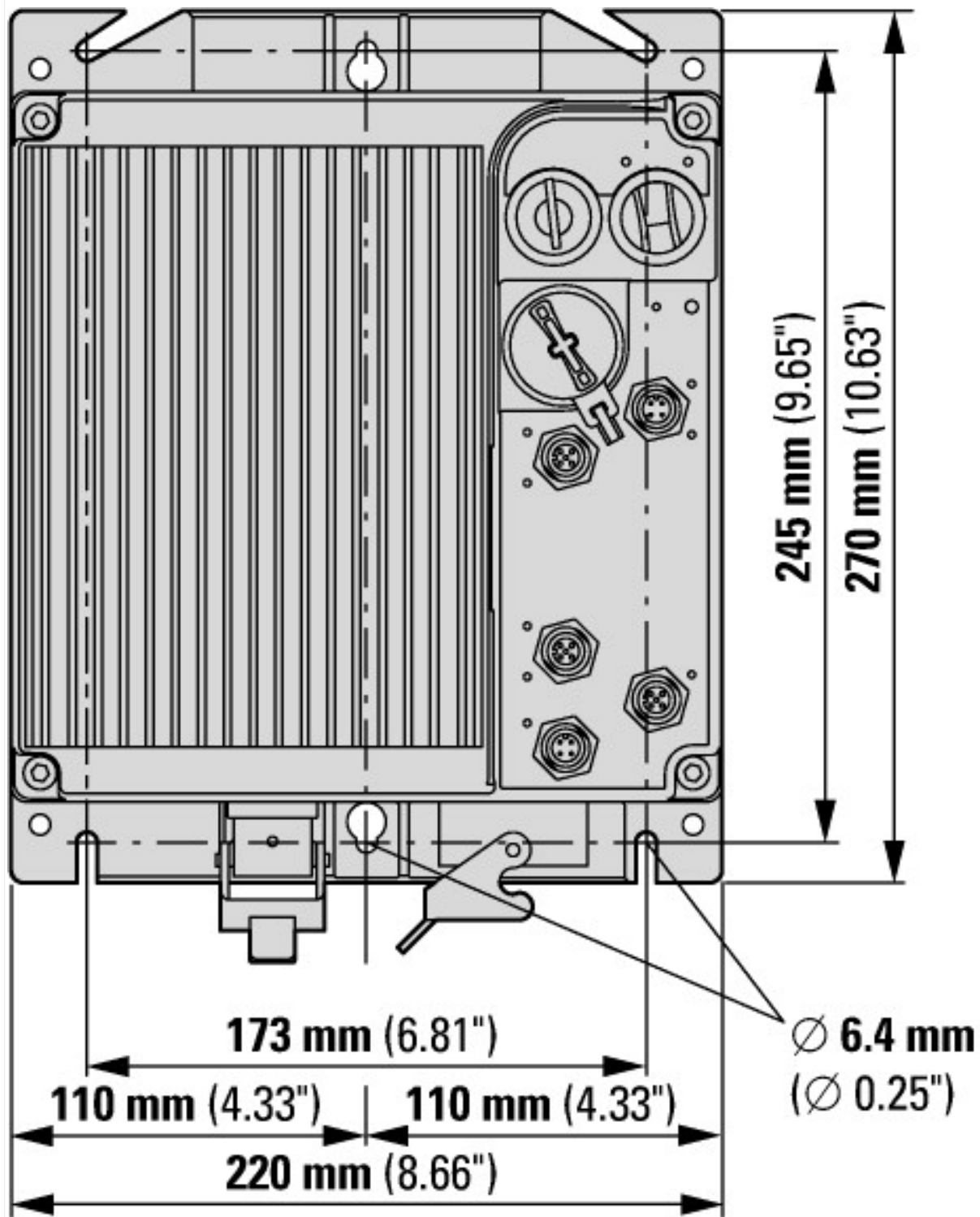

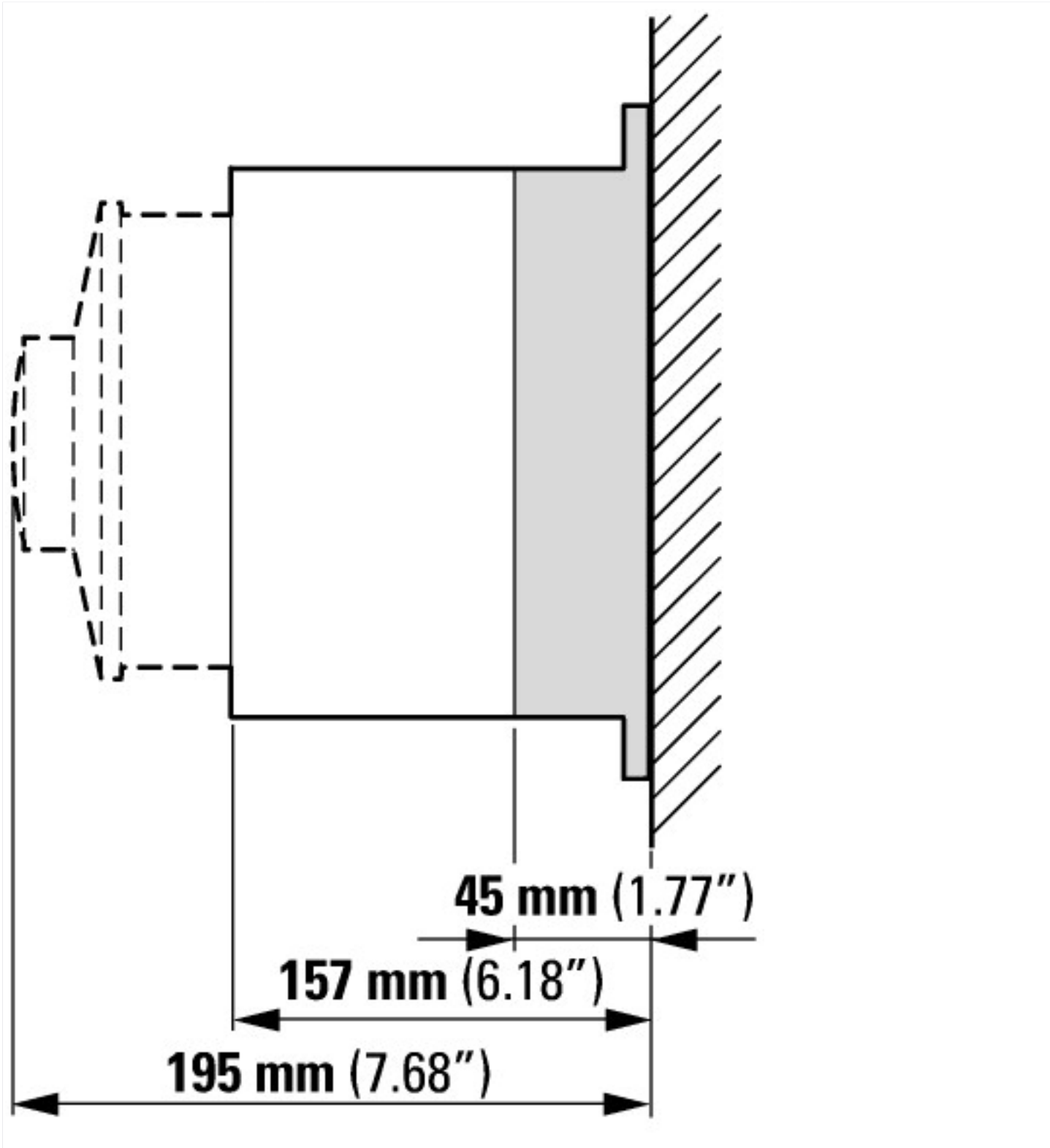

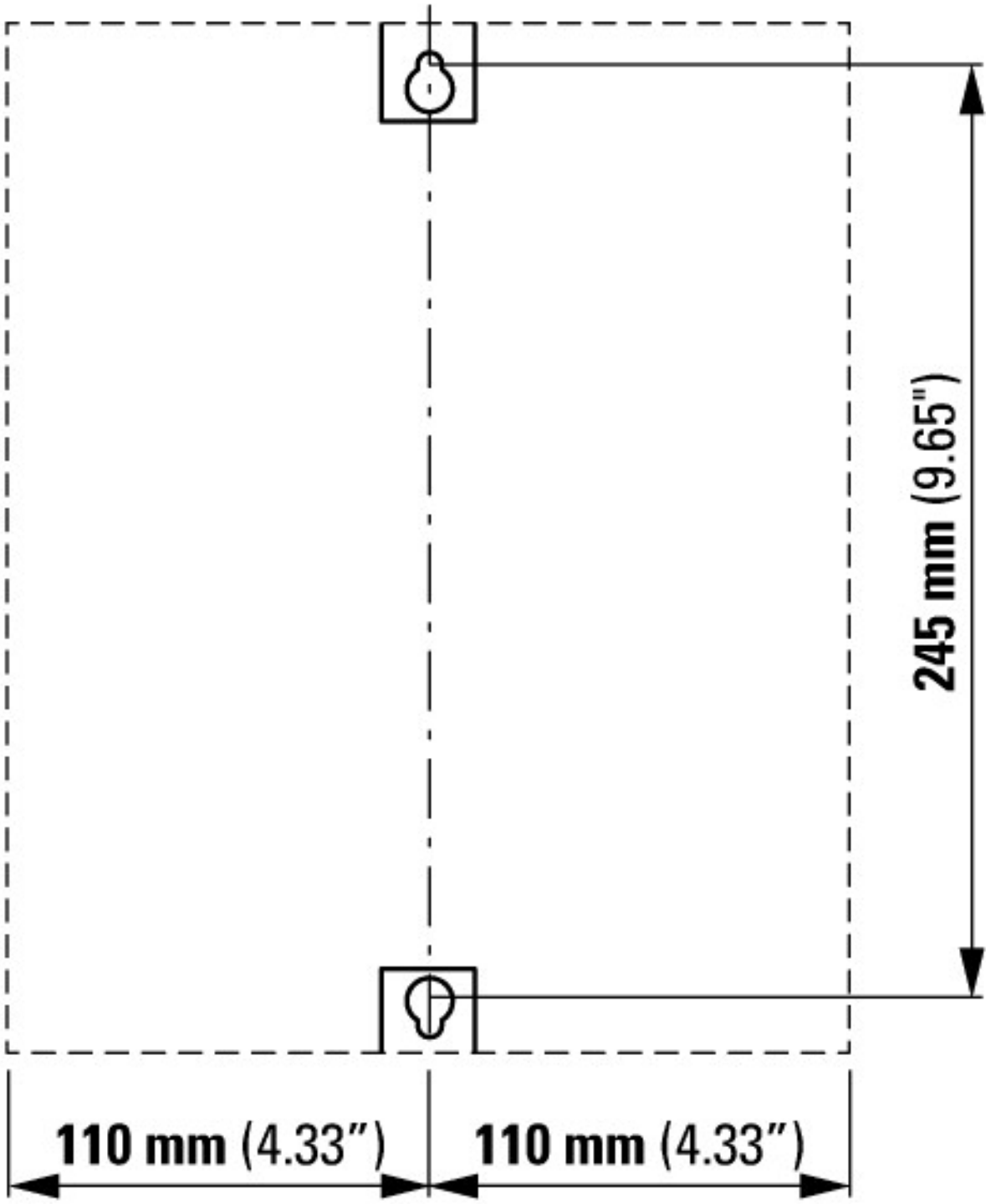

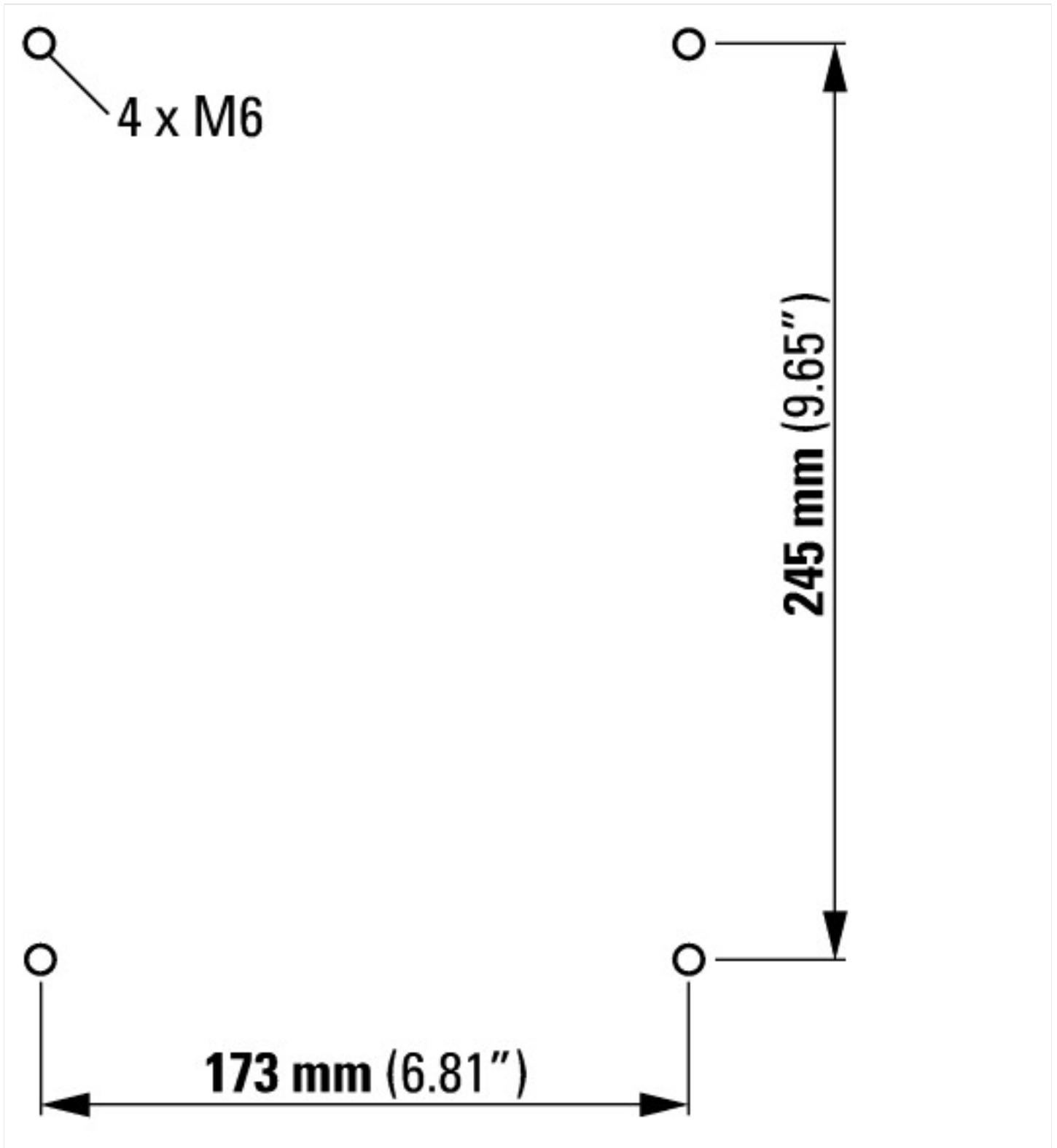

Additional product information (links)

IL034085ZU Rapid Link 5 Speed Control Unit

IL034085ZU Rapid Link 5 Speed Control Unit https://es-assets.eaton.com/DOCUMENTATION/AWA_INSTRUCTIONS/IL034085ZU2020_06.pdf

MN034004 Rapid Link 5.0 RAMO RASP

MN034004 Schnellverbindung 5.0 RAMO RASP https://es-assets.eaton.com/DOCUMENTATION/AWB_MANUALS/MN034004_DE.pdf
- Deutsch

MN034004 Rapid Link 5.0 RAMO RASP - English https://es-assets.eaton.com/DOCUMENTATION/AWB_MANUALS/MN034004EN.pdf