



Reversing starter, 6.6 A, Sensor input 2, Actuator output 1, 230/277 V AC, AS-Interface®, S-7.A.E. for 62 modules, HAN Q5



Part no. **RAM05-W212A32-5120S1**  
 Catalog No. **198540**

## Delivery program

Product range			Motor starter
Basic function			Reversing starter
Rated operational voltage	$U_e$		400 V AC, 3-phase 480 V AC, 3-phase
Output voltage with $V_e$	$U_2$		= $U_{LN}$
Mains voltage (50/60Hz)	$U_{LN}$	V	380 (-15%) - 480 (+10%)
At 150% overload	$I_e$	A	6.6
<b>assigned motor rating P</b>			
Note			at 400 V, 50 Hz
150 % Overload	P	kW	0,09 - 3
Note			at 480 V, 60 Hz
150 % Overload	P	HP	0,125 - 3
Note			for normal internally and externally ventilated 4 pole, three-phase asynchronous motors with $1500 \text{ rpm}^{-1}$ at 50 Hz or $1800 \text{ min}^{-1}$ at 60 Hz
Description			Integrated thermistor monitoring PTC and thermo-click Two sensor inputs through M12 sockets (max. 150 mA) for quick stop and interlocked manual operation Connections pluggable in power section Connection of supply voltage via adapter cable on round or flexible busbar junction Diagnostics and reset on device and via AS-Interface with AUTO - OFF/RESET - HAND key switches With electronic motor protection for allocated motor power from 0.09 – 3.0 kW (400 V)/0.125 – 3.0 HP (480 V)
Sensor input		Number	2
Actuator output		Number	1
Control voltage external brake (50/60 Hz)		V	230/277 V AC
Interface/field bus (built-in)			AS-Interface®
AS-Interface profile cable			S-7.A.E. for 62 modules
Plug arrangement			HAN Q5
Parameterization			Keypad Fieldbus drivesConnect drivesConnect mobile (App)
<b>Instructions</b> for actuation of motors with mechanical brake			

## Technical data

### General

Standards			IEC/EN 60947-4-2 UL 60947-4-2 Guideline 2011/65/EU (RoHS) CE approval UL approval CCC approval
Climatic proofing	$\rho_w$	%	< 95%, non-condensing IEC/EN 50178
Ambient temperature			
Operating ambient temperature min.		°C	-10
Operating ambient temperature max.		°C	+55
Storage	$\theta$	°C	-40 - +70
Overvoltage category			III
Rated impulse withstand voltage	$U_{imp}$	kV	4
Radio interference level			
Environment (EMC)			Device class A

maximum motor cable length	l	m	10
Mechanical shock resistance		g	1000 shocks per shaft, semi-sinusoidal 15 g/11 ms IEC/EN 60068-2-27
Vibration			Oscillation frequency: 10 - 150 Hz Amplitude 0.15 mm: 6 Hz Amplitude transition frequency on acceleration: 57 Hz IEC/EN 60068-2-6
Mounting position			Vertical
Altitude		m	0 - 1000 m above sea level above 1000 m with 1 % performance reduction per 100 m max. 2000 m
Degree of Protection			IP65 NEMA12

### Main circuit

Supply			
Rated operational voltage	$U_e$		400 V AC, 3-phase 480 V AC, 3-phase
Mains voltage (50/60Hz)	$U_{LN}$	V	380 (-15%) - 480 (+10%)
Input current (150% overload)	$I_{LN}$	A	6.6
System configuration			AC voltage Center-point earthed star network (TN-S network) Phase-earthed AC supply systems are not permitted.
Supply frequency	$f_{LN}$	Hz	50/60
Frequency range	$f_{LN}$	Hz	47 - 63 Hz ( $\pm 0\%$ )
Mains switch-on frequency			Maximum of one time every 60 seconds
Rated conditional short-circuit current	$I_q$	kA	< 10
Short-circuit protection for output circuits, external			Type 1 coordination via the power bus' feeder unit
Power section			
Function			Reversing starter with relays, thyristors and bypass contacts, 2-phase controlled
On-delay	$t_{ON}$	ms	20 - 35
Off-delay	$t_{OFF}$	ms	20 - 35
Lifespan, mechanical	Operations		AC3: > 10.000.000
Lifespan, electrical	Operations		AC3: > 10.000.000
Overload cycle			AC-53a
Output voltage with $V_e$	$U_2$		= $U_{LN}$
Output Frequency	$f_2$	Hz	= $f_{LN}$
Rated operational current			
At 150% overload	$I_e$	A	6.6
Motor current limit	$I$	A	0.3 - 6.6 adjustable
Fitted with			without manual override switch
Motor feeder			
Note			for normal internally and externally ventilated 4 pole, three-phase asynchronous motors with 1500 rpm <sup>-1</sup> at 50 Hz or 1800 min <sup>-1</sup> at 60 Hz
Note			at 400 V, 50 Hz
Note			at 480 V, 60 Hz
Actuator for external motor brake			
Breaking voltage	$U$	V	230/277 V AC -15% / +10%
Braking current	$I$	A	≤ 0.6 A (max. 6 A for 120 ms)

### Control section

External control voltage	$U_c$	V	24 V DC - 15 % / + 20 % via AS-Interface® plug
Interface/field bus (built-in)			AS-Interface®
AS-Interface®			max. total power consumption from AS-Interface® power supply unit (30 V): 190 mA Specification: S-7.A.E. Number of slave addresses: 62

### Design verification as per IEC/EN 61439

Technical data for design verification			
Operating ambient temperature min.		°C	-10

Operating ambient temperature max.

°C

55

## Technical data ETIM 7.0

Low-voltage industrial components (EG000017) / Motor starter/Motor starter combination (EC001037)

Electric engineering, automation, process control engineering / Low-voltage switch technology / Load breakout, motor breakout / Motor starter combination (ecl@ss10.0.1-27-37-09-05 [AJZ718013])

Kind of motor starter		Reversing starter
With short-circuit release		Yes
Rated control supply voltage Us at AC 50HZ	V	0 - 0
Rated control supply voltage Us at AC 60HZ	V	0 - 0
Rated control supply voltage Us at DC	V	29 - 32
Voltage type for actuating		DC
Rated operation power at AC-3, 230 V, 3-phase	kW	0
Rated operation power at AC-3, 400 V	kW	3
Rated power, 460 V, 60 Hz, 3-phase	kW	2.238
Rated power, 575 V, 60 Hz, 3-phase	kW	0
Rated operation current Ie	A	6.6
Rated operation current at AC-3, 400 V	A	6.6
Overload release current setting	A	0.3 - 6.6
Rated conditional short-circuit current, type 1, 480 Y/277 V	A	100000
Rated conditional short-circuit current, type 1, 600 Y/347 V	A	0
Rated conditional short-circuit current, type 2, 230 V	A	0
Rated conditional short-circuit current, type 2, 400 V	A	0
Number of auxiliary contacts as normally open contact		1
Number of auxiliary contacts as normally closed contact		0
Ambient temperature, upper operating limit	°C	55
Temperature compensated overload protection		Yes
Release class		CLASS 10
Type of electrical connection of main circuit		Plug-in connection
Type of electrical connection for auxiliary- and control current circuit		Other
Rail mounting possible		No
With transformer		No
Number of command positions		2
Suitable for emergency stop		No
Coordination class according to IEC 60947-4-3		Class 1
Number of indicator lights		8
External reset possible		Yes
With fuse		No
Degree of protection (IP)		IP65
Degree of protection (NEMA)		12
Supporting protocol for TCP/IP		No
Supporting protocol for PROFIBUS		No
Supporting protocol for CAN		No
Supporting protocol for INTERBUS		No
Supporting protocol for ASI		Yes
Supporting protocol for MODBUS		No
Supporting protocol for Data-Highway		No
Supporting protocol for DeviceNet		No
Supporting protocol for SUCONET		No
Supporting protocol for LON		No
Supporting protocol for PROFINET IO		No
Supporting protocol for PROFINET CBA		No
Supporting protocol for SERCOS		No
Supporting protocol for Foundation Fieldbus		No
Supporting protocol for EtherNet/IP		No
Supporting protocol for AS-Interface Safety at Work		No

Supporting protocol for DeviceNet Safety		No
Supporting protocol for INTERBUS-Safety		No
Supporting protocol for PROFIsafe		No
Supporting protocol for SafetyBUS p		No
Supporting protocol for other bus systems		No
Width	mm	220
Height	mm	270
Depth	mm	120

## Dimensions

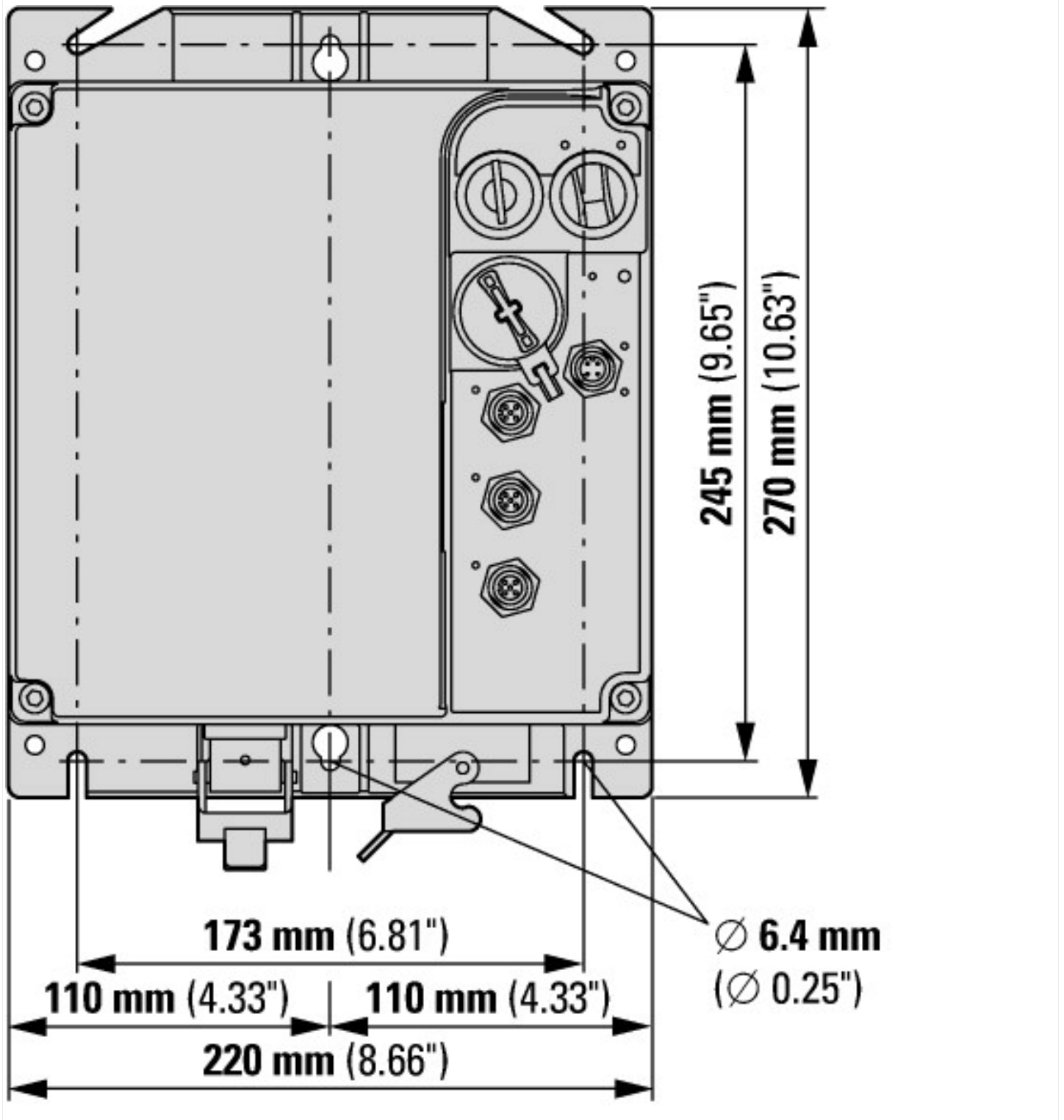

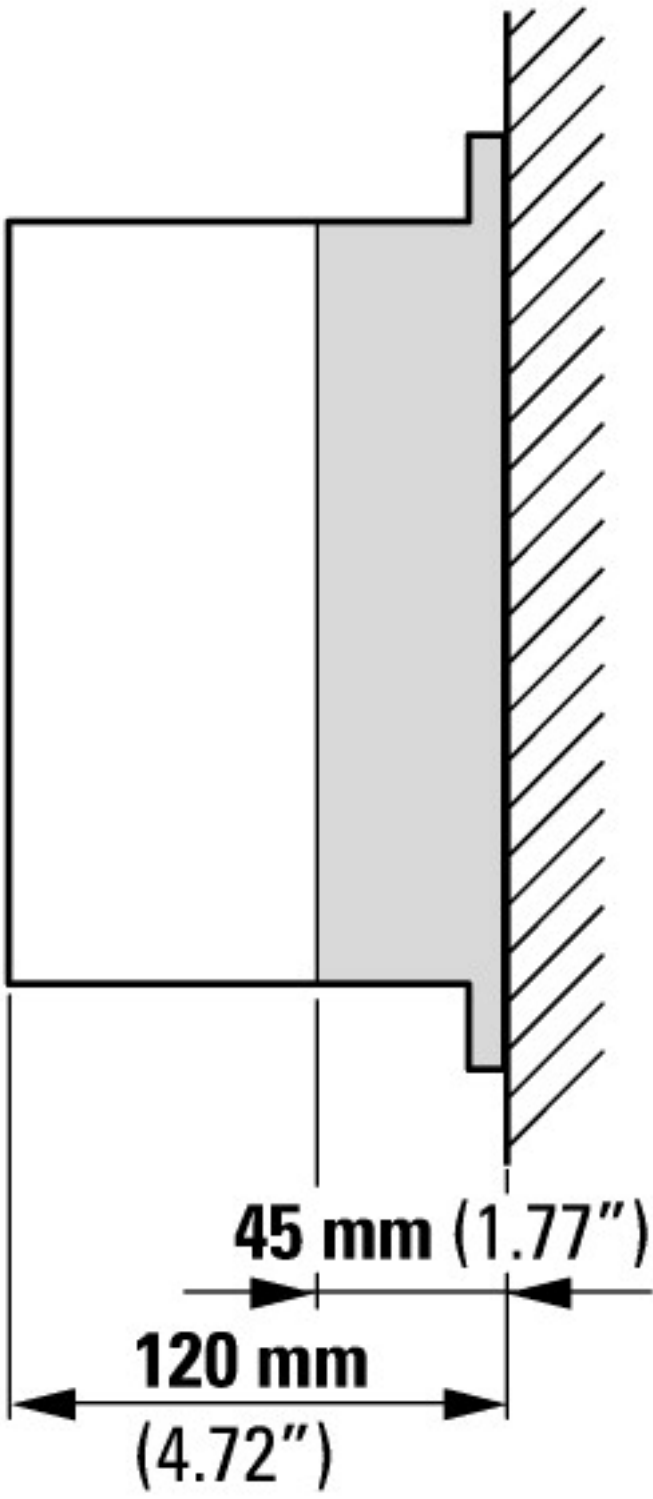

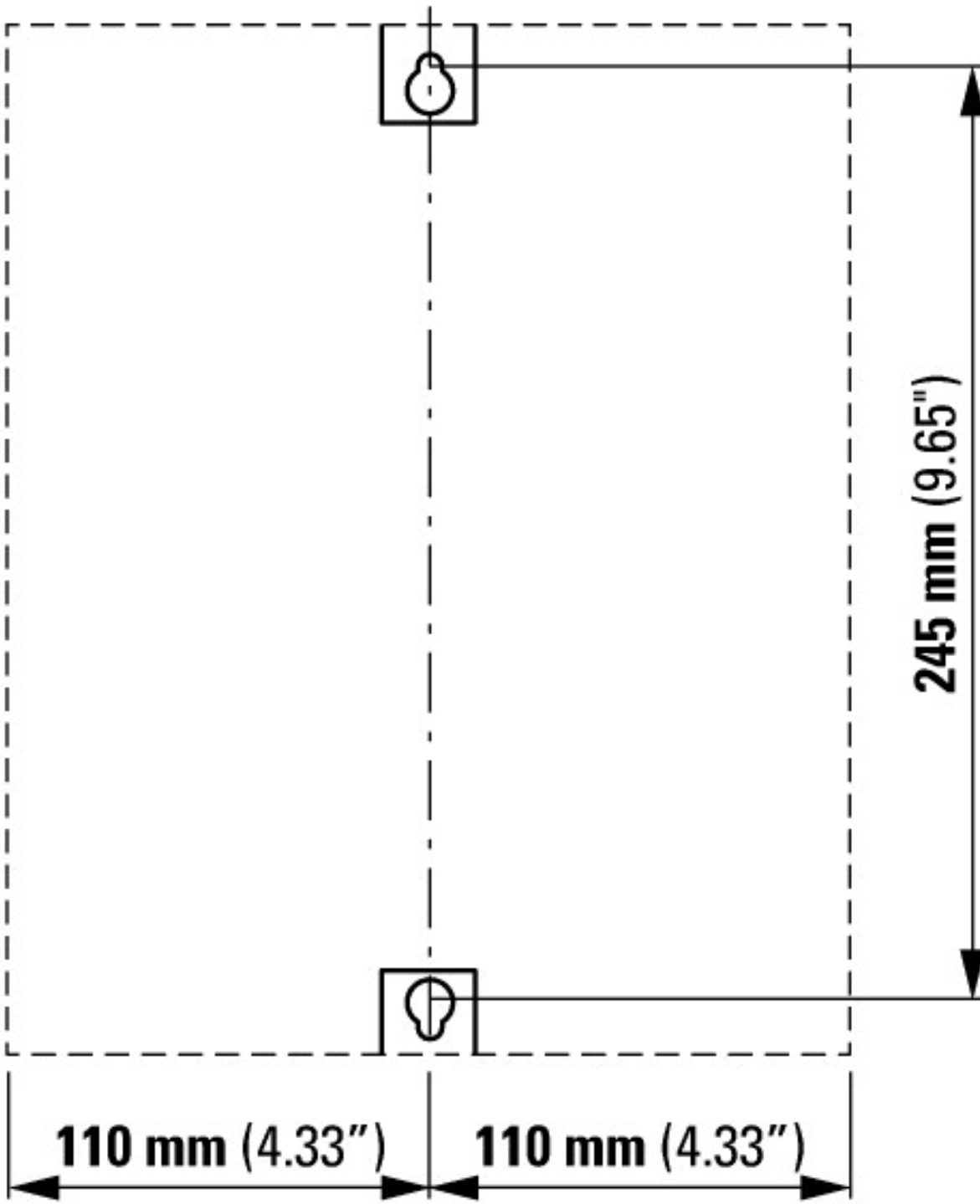

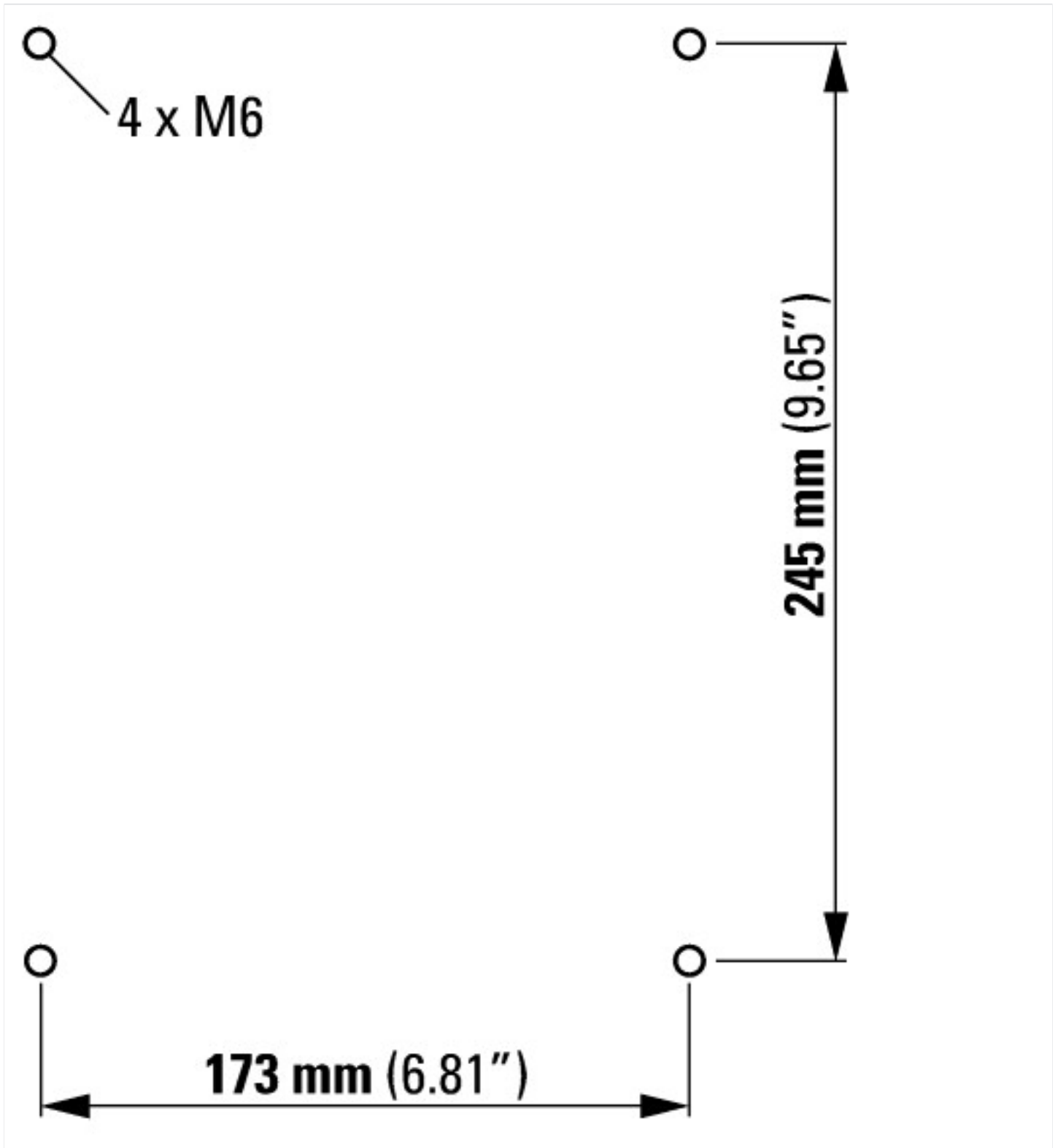

### Additional product information (links)

#### IL034084ZU Rapid Link 5 Motor Control Unit

IL034084ZU Rapid Link 5 Motor Control Unit [https://es-assets.eaton.com/DOCUMENTATION/AWA\\_INSTRUCTIONS/IL034084ZU2020\\_09.pdf](https://es-assets.eaton.com/DOCUMENTATION/AWA_INSTRUCTIONS/IL034084ZU2020_09.pdf)

#### MN034004 Rapid Link 5.0 RAMO RASP

MN034004 Schnellverbindung 5.0 RAMO RASP - Deutsch [https://es-assets.eaton.com/DOCUMENTATION/AWB\\_MANUALS/MN034004\\_DE.pdf](https://es-assets.eaton.com/DOCUMENTATION/AWB_MANUALS/MN034004_DE.pdf)

MN034004 Rapid Link 5.0 RAMO RASP - English [https://es-assets.eaton.com/DOCUMENTATION/AWB\\_MANUALS/MN034004EN.pdf](https://es-assets.eaton.com/DOCUMENTATION/AWB_MANUALS/MN034004EN.pdf)

MN034004 Rapid Link 5.0 RAMO RASP - English [https://es-assets.eaton.com/DOCUMENTATION/AWB\\_MANUALS/MN034004\\_EN.pdf](https://es-assets.eaton.com/DOCUMENTATION/AWB_MANUALS/MN034004_EN.pdf)