



Speed controllers, 4.3 A, 1.5 kW, Sensor input 4, Actuator output 2, Ethernet IP, HAN Q4/2, with manual override switch, with braking resistance, STO (Safe Torque Off)



Part no. RASP5-4420EIP-412R110S1  
 Catalog No. 198896

## Delivery program

Product range			Speed controller
Rated operational voltage	$U_e$		400 V AC, 3-phase 480 V AC, 3-phase
Output voltage with $V_e$	$U_2$		0 - $U_{LN}$
Mains voltage (50/60Hz)	$U_{LN}$	V	380 (-15%) - 480 (+10%)
At 150% overload	$I_e$	A	4.3
<b>assigned motor rating P</b>			
Note			at 400 V, 50 Hz
150 % Overload	P	kW	1.5
Note			at 480 V, 60 Hz
150 % Overload	P	HP	2
Note			for normal internally and externally ventilated 4 pole, three-phase asynchronous motors with $1500 \text{ rpm}^{-1}$ at 50 Hz or $1800 \text{ min}^{-1}$ at 60 Hz
Description			integrated PTC thermistor monitoring and Thermoclick with safe isolation Two sensor inputs through M12 sockets (max. 150 mA) for quick stop and interlocked manual operation optional: 4 sensor inputs with M12-Y adapter for switchover to creep speed Connection of supply voltage via adapter cable on round or flexible busbar junction Diagnostics and reset on the device and via Ethernet IP with AUTO - OFF/RESET - HAND key switches 3 fixed speeds and 1 potentiometer speed can be switched over from U/f to (vector) speed control with selector switch REV - OFF - FWD optional: Faster stop if external 24 V fails
Sensor input		Number	4
Actuator output		Number	2
Interface/field bus (built-in)			Ethernet IP
Plug arrangement			HAN Q4/2
Repair switch			with manual override switch
Braking resistance			with braking resistance
Safety function			STO (Safe Torque Off)
Parameterization			Keypad Fieldbus drivesConnect drivesConnect mobile (App)
<b>Instructions</b> integrated brake chopper with braking resistance for dynamic braking			

## Technical data

<b>General</b>			
Standards			IEC/EN 61800-5-1 UL 61800-5-1 Guideline 2011/65/EU (RoHS) CE approval UL approval
Climatic proofing	$\rho_w$	%	< 95%, non-condensing IEC/EN 50178
Ambient temperature			
Operating ambient temperature min.		°C	-10
Operating ambient temperature max.		°C	+40
			-10 – +55 with derating
Storage	$\theta$	°C	-40 - +70
Overvoltage category			III
Rated impulse withstand voltage	$U_{imp}$	kV	2

Radio interference level			
Radio interference class (EMC)			C1 (for conducted emissions only), C2, C3, depending on the motor cable length, the connected load, and ambient conditions.
Environment (EMC)			1st and 2nd environments as per EN 61800-3
maximum motor cable length	l	m	C1 ≤ 1 m C2 ≤ 5 m C3 ≤ 25 m
Mechanical shock resistance		g	1000 shocks per shaft, semi-sinusoidal 15 g/11 ms IEC/EN 60068-2-27
Vibration			Oscillation frequency: 10 - 150 Hz Amplitude 0.15 mm: 6 Hz Amplitude transition frequency on acceleration: 57 Hz IEC/EN 60068-2-6
Mounting position			Vertical
Altitude		m	0 - 1000 m above sea level above 1000 m with 1 % performance reduction per 100 m max. 2000 m
Degree of Protection			IP65 NEMA12

## Main circuit

Supply			
Rated operational voltage	$U_e$		400 V AC, 3-phase 480 V AC, 3-phase
Mains voltage (50/60Hz)	$U_{LN}$	V	380 (-15%) - 480 (+10%)
Input current (150% overload)	$I_{LN}$	A	4.1
System configuration			AC voltage Center-point earthed star network (TN-S network) Phase-earthed AC supply systems are not permitted.
Supply frequency	$f_{LN}$	Hz	50/60
Frequency range	$f_{LN}$	Hz	45–66 (± 0%)
Mains switch-on frequency			Maximum of one time every 60 seconds
Mains current distortion	THD	%	< 120
Rated conditional short-circuit current	$I_q$	kA	< 10
Short-circuit protection for output circuits, external			Type 1 coordination via the power bus' feeder unit
Power section			
Function			Variable frequency drive with internal DC link and IGBT inverter
On-delay	$t_{0N}$	ms	< 10
Off-delay	$t_{0FF}$	ms	< 10
Overload current (150% overload)	$I_L$	A	6.5
Note regarding overload current			For 60 s every 600 s at 40 °C
max. starting current (High Overload)	$I_H$	%	200
Note about max. starting current			at 40 °C
Output voltage with $V_e$	$U_2$		0 - $U_{LN}$
Output Frequency	$f_2$	Hz	0 - 50/60 (max. 500)
Switching frequency	$f_{PWM}$	kHz	8 adjustable 4 - 32
Operation Mode			U/f control sensorless vector control (SLV) PM and LSPM motors Synchronous reluctance motors BLDC motors
Frequency resolution (setpoint value)	$\Delta f$	Hz	0.1
Rated operational current			
At 150% overload	$I_e$	A	4.3
Note			Rated operational current at a switching frequency of 8 kHz and an ambient air temperature of +40 °C
Motor current limit	l	A	0,4 - 4,3 adjustable
Power loss			
Heat dissipation at rated operational current $I_e = 150\%$	$P_V$	W	46
Efficiency	$\eta$	%	98
Maximum leakage current to ground (PE) without motor	$I_{PE}$	mA	3.5

Fitted with			with manual override switch without fan with braking resistance
Safety function			STO (Safe Torque Off)
Motor feeder			
Note			for normal internally and externally ventilated 4 pole, three-phase asynchronous motors with $1500 \text{ rpm}^{-1}$ at 50 Hz or $1800 \text{ min}^{-1}$ at 60 Hz
Note			at 400 V, 50 Hz
150 % Overload	P	kW	1.5
Note			at 480 V, 60 Hz
150 % Overload	P	HP	2
Braking function			
Switch-on threshold for the braking transistor	$U_{DC}$	V	765 V DC
DC braking	%	$I/I_e$	$\leq 100$ , adjustable

### Control section

External control voltage	$U_c$	V	24 V DC - 15 % / + 20 % via AS-Interface® plug
Interface/field bus (built-in)			Ethernet IP
AS-Interface®			max. total power consumption from AS-Interface® power supply unit (30 V): 250 mA Specification: S-7.4 Number of slave addresses: 31

### Design verification as per IEC/EN 61439

Technical data for design verification			
Operating ambient temperature min.		°C	-10
Operating ambient temperature max.		°C	40

### Technical data ETIM 7.0

Low-voltage industrial components (EG000017) / Frequency converter =< 1 kV (EC001857)

Electric engineering, automation, process control engineering / Electrical drive / Static frequency converter / Static frequency converter = < 1 kV (ec@ss10.0.1-27-02-31-01 [AKE177014])

Mains voltage		V	342 - 868
Mains frequency			50/60 Hz
Number of phases input			3
Number of phases output			3
Max. output frequency		Hz	500
Max. output voltage		V	500
Nominal output current I <sub>2N</sub>		A	4.3
Max. output at quadratic load at rated output voltage		kW	1.5
Max. output at linear load at rated output voltage		kW	1.5
Relative symmetric net frequency tolerance		%	10
Relative symmetric net voltage tolerance		%	10
Number of analogue outputs			0
Number of analogue inputs			0
Number of digital outputs			2
Number of digital inputs			4
With control unit			Yes
Application in industrial area permitted			Yes
Application in domestic- and commercial area permitted			Yes
Supporting protocol for TCP/IP			No
Supporting protocol for PROFIBUS			No
Supporting protocol for CAN			No
Supporting protocol for INTERBUS			No
Supporting protocol for ASI			No
Supporting protocol for KNX			No
Supporting protocol for MODBUS			No
Supporting protocol for Data-Highway			No
Supporting protocol for DeviceNet			No

Supporting protocol for SUCONET		No
Supporting protocol for LON		No
Supporting protocol for PROFINET IO		No
Supporting protocol for PROFINET CBA		No
Supporting protocol for SERCOS		No
Supporting protocol for Foundation Fieldbus		No
Supporting protocol for EtherNet/IP		Yes
Supporting protocol for AS-Interface Safety at Work		No
Supporting protocol for DeviceNet Safety		No
Supporting protocol for INTERBUS-Safety		No
Supporting protocol for PROFIsafe		No
Supporting protocol for SafetyBUS p		No
Supporting protocol for BACnet		No
Supporting protocol for other bus systems		No
Number of HW-interfaces industrial Ethernet		2
Number of interfaces PROFINET		0
Number of HW-interfaces RS-232		0
Number of HW-interfaces RS-422		0
Number of HW-interfaces RS-485		1
Number of HW-interfaces serial TTY		0
Number of HW-interfaces USB		0
Number of HW-interfaces parallel		0
Number of HW-interfaces other		0
With optical interface		No
With PC connection		Yes
Integrated breaking resistance		Yes
4-quadrant operation possible		Yes
Type of converter		U converter
Degree of protection (IP)		IP65
Degree of protection (NEMA)		12
Height	mm	278
Width	mm	220
Depth	mm	157

## Dimensions

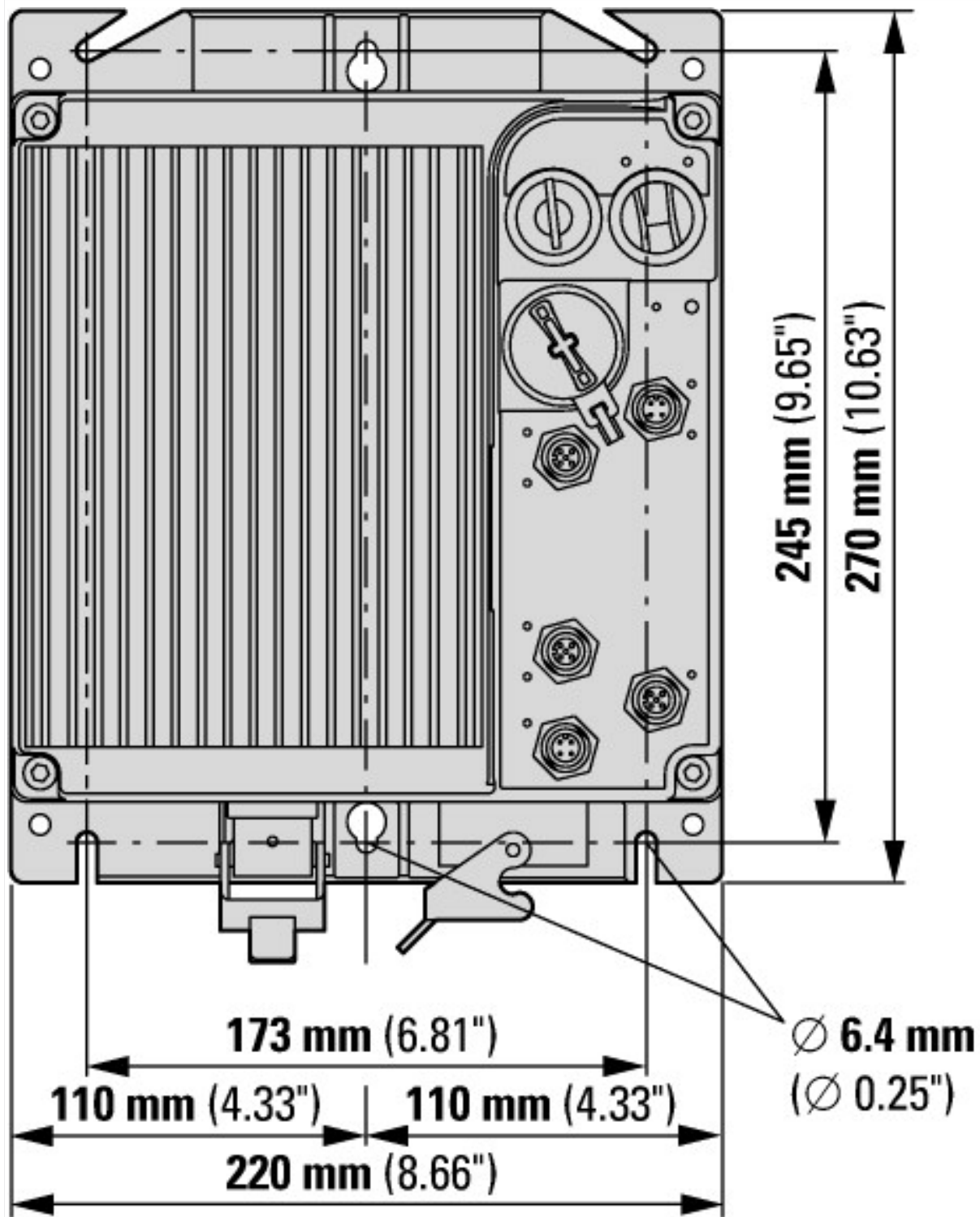

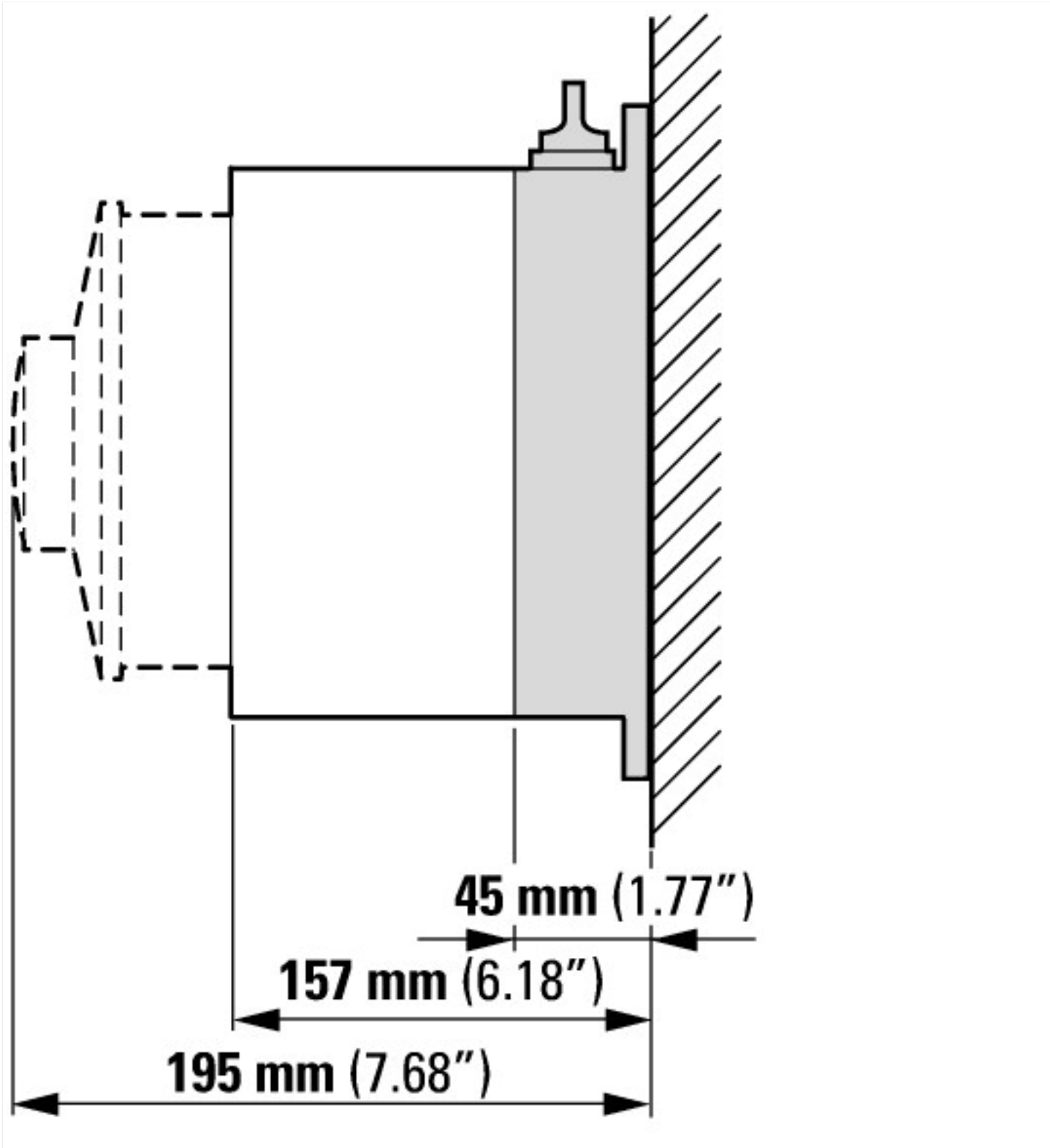

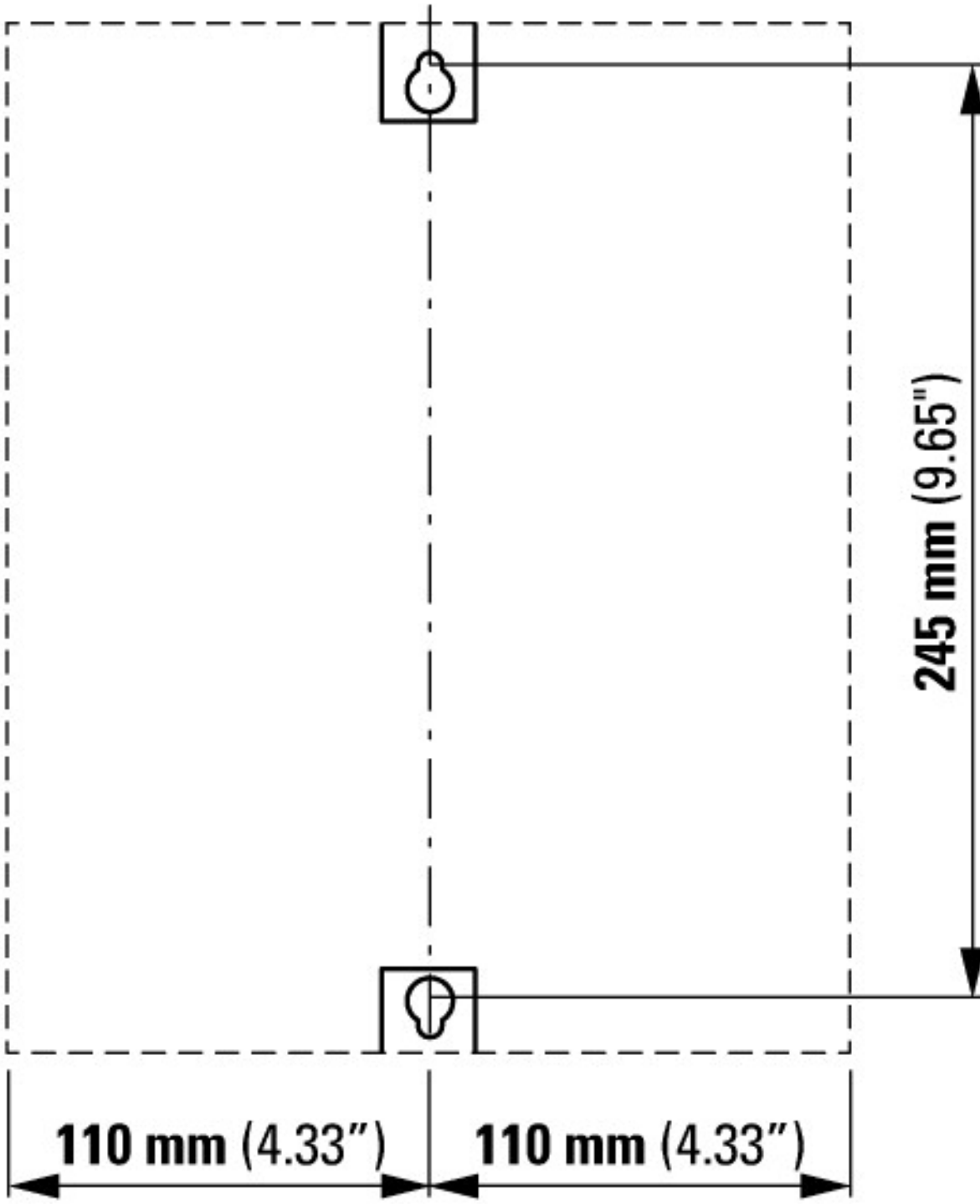

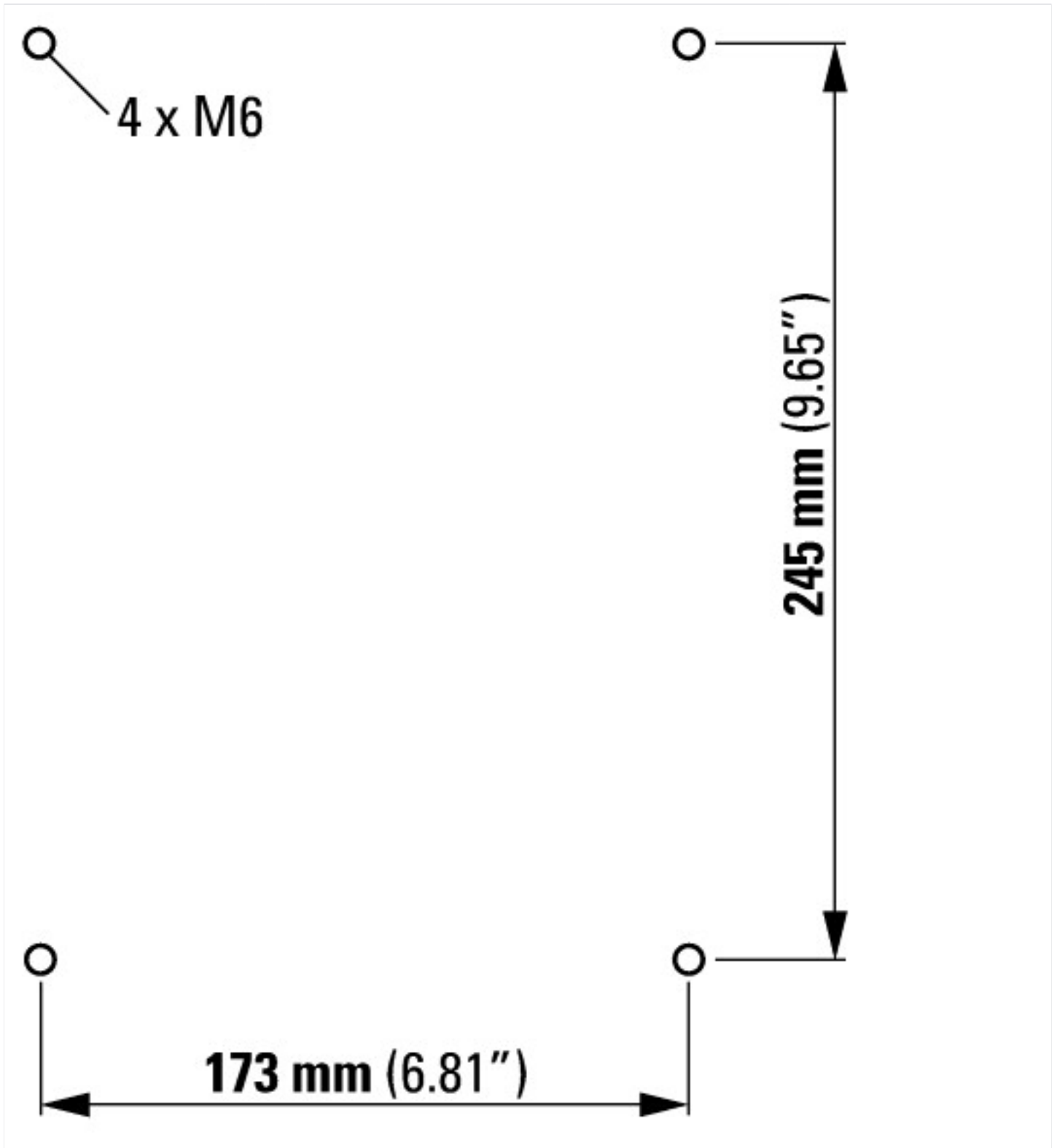

### Additional product information (links)

#### IL034085ZU Rapid Link 5 Speed Control Unit

IL034085ZU Rapid Link 5 Speed Control Unit [https://es-assets.eaton.com/DOCUMENTATION/AWA\\_INSTRUCTIONS/IL034085ZU2020\\_09.pdf](https://es-assets.eaton.com/DOCUMENTATION/AWA_INSTRUCTIONS/IL034085ZU2020_09.pdf)

#### MN034004 Rapid Link 5.0 RAMO RASP

MN034004 Schnellverbindung 5.0 RAMO RASP - Deutsch [https://es-assets.eaton.com/DOCUMENTATION/AWB\\_MANUALS/MN034004\\_DE.pdf](https://es-assets.eaton.com/DOCUMENTATION/AWB_MANUALS/MN034004_DE.pdf)

MN034004 Rapid Link 5.0 RAMO RASP - English [https://es-assets.eaton.com/DOCUMENTATION/AWB\\_MANUALS/MN034004EN.pdf](https://es-assets.eaton.com/DOCUMENTATION/AWB_MANUALS/MN034004EN.pdf)

MN034004 Rapid Link 5.0 RAMO RASP - English [https://es-assets.eaton.com/DOCUMENTATION/AWB\\_MANUALS/MN034004\\_EN.pdf](https://es-assets.eaton.com/DOCUMENTATION/AWB_MANUALS/MN034004_EN.pdf)