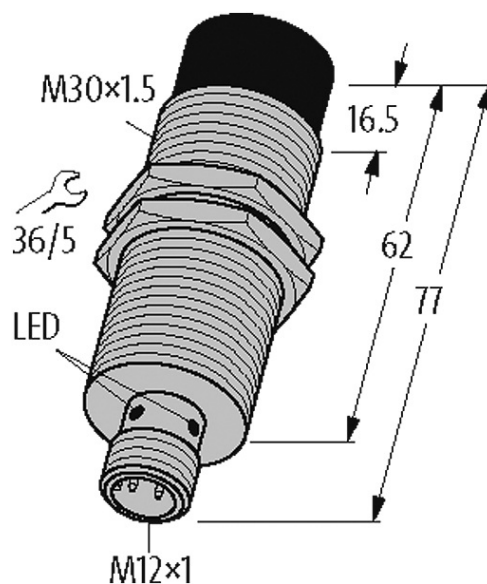

Inductive coupler IO-Link V1.1 primary Male M12 M30

Port Class A

IO-Link Coupler (prim.)
M12 (4-pole)
IO-Link V1.1

Connection cables are in the online shop under "Connection Technology".

[Link to Product](#)**Illustration**

Product may differ from Image

Connections

IO-Link

M12 (male) 4-pole, A-coded

Supply (prim.)

Operating voltage	24 V DC \pm 10%
-------------------	-------------------

Operating current	750 mA
-------------------	--------

Technical Data

Nominal distance	0...7 mm (prim./sec.)
------------------	-----------------------

Standby power (coupled)	4 W
-------------------------	-----

Standby power (uncoupled)	1 W
---------------------------	-----

Short-circuit protection	yes
--------------------------	-----

Invers-polarity protection	yes
----------------------------	-----

Rotation	1 250 rpm
----------	-----------

General data

Protection	IP67/IP68
------------	-----------

Material (housing)	Brass, chrome plated
--------------------	----------------------

Labeling	Laser labelled
----------	----------------

Temperature range	-20...+55 °C
-------------------	--------------

Dimensions H x W x D	30x30x77 mm
----------------------	-------------

IO-Link

Specification	IO-Link V1.1
---------------	--------------

Operating modes	COM2 (38.4 kBit/s)
-----------------	--------------------

Port Class	A
------------	---

Diagnostic

Communication status	via LED
----------------------	---------

Diagnostic via LED	yes
--------------------	-----

Commercial data

country of origin	CZ
-------------------	----

customs tariff number	85389099
-----------------------	----------

EAN	4048879677912
-----	---------------

eClass	27242604
--------	----------

Packaging unit	1
----------------	---