

## AMMP 12/9

Adaptor, brass nickel-plated, M12 / Pg9

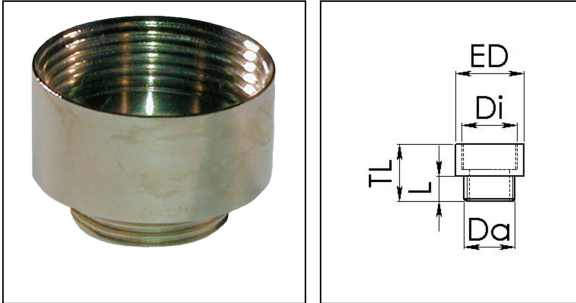

Products may differ in size, colour and appearance to those shown. If you require further information or customisation, please contact us directly.



<b>Material</b>	Brass nickel-plated
<b>Temp. range min</b>	-200 °C
<b>Temp. range max</b>	250 °C
<b>Thread type outer</b>	M
<b>Ø outer thread</b>	12
<b>Lead outer</b>	1,5
<b>Length screw-in thread L</b>	6 mm
<b>Thread type inner</b>	PG
<b>Ø inner thread</b>	9
<b>Length internal thread</b>	9 mm
<b>External diameter ED</b>	17 mm
<b>Total length TL</b>	16 mm
<b>Form</b>	A
<b>Surface</b>	Nickel-plated
<b>Order no. nickel-plated</b>	10063912
<b>Type</b>	AMMP 12/9
<b>Packing unit</b>	100
<b>ETIM-Classification</b>	EC000938

### Recommended accessories

<b>EMMU 12</b>	10063141
<b>ORD-E 12 + PG7</b>	10064697

14.01.2021

Your Contact:

WISKA Hoppmann GmbH

Kisdorfer Weg 28 · 24568 Kaltenkirchen · Germany

☎ +49-4191-508-0 · 📠 +49-4191-508-209

contact@wiska.de · www.wiska.com

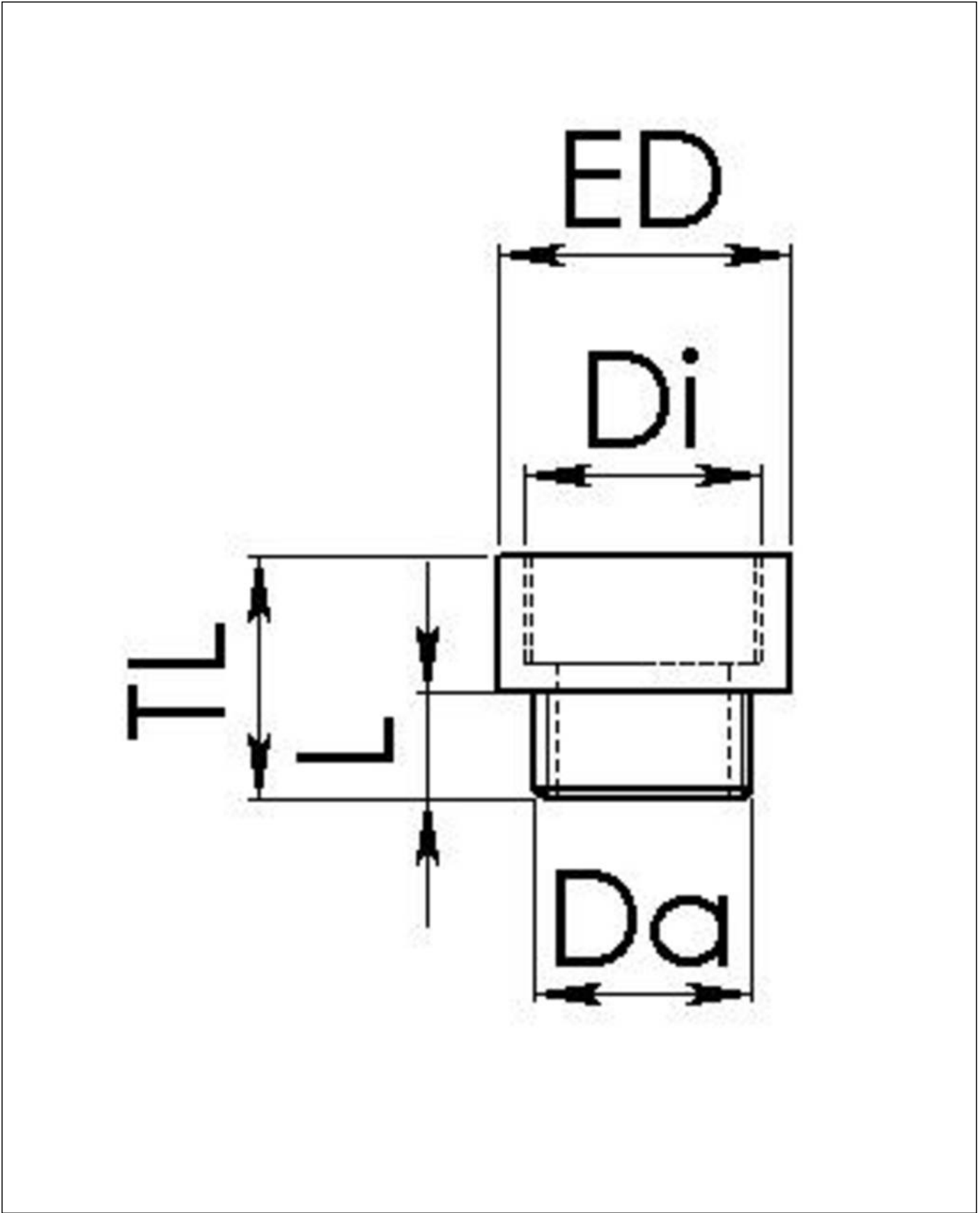

Your Contact:  
**WISKA Hoppmann GmbH**  
Kisdorfer Weg 28 · 24568 Kaltenkirchen · Germany  
☎ +49-4191-508-0 · 📠 +49-4191-508-209  
contact@wiska.de · www.wiska.com